

TANA



CE



ODL 电动执行器系列
ODL Series Electric Actuator

概述 Summary

“ODL”系列电动执行器用于控制0°~270°旋转的阀门及其他同类产品，如蝶阀、球阀、风门、挡板阀、旋塞阀、百叶阀等，可以广泛应用于石油、化工、水处理、船舶、造纸、电站、供热，轻工等各行各业中。它以380V/220V/110V交流电源或24V/110V直流电源为驱动电源，以4~20mA电流信号或0~10V DC电压信号为控制信号，可使阀门运动到所需位置，实现其自动化控制，最大输出扭矩达4000N·m。

"ODL" series electric actuator is used for control 0°~270° rotation of the valves and other similar products, such as butterfly valve, ball valve, damper, flapper valves, cock valves, etc. It's widely used in petroleum, chemical, water treatment, shipping, paper making, power plants, heating, light industry and other industries. It drives by 380V/220V/110V AC power. Control signal is 4~20mA current signal or 0~10V DC voltage signal, enables move the valve to the desired position, achieving its automation, maximum output torque is up to 4000N·m.

性能特点 performance Features

- 壳体**--壳体为硬质铝合金，经阳极氧化处理和聚酯粉末涂层，耐腐蚀性强，防护等级为IP67, NEMA4和6，并有IP68型供选择。
Shell--The shell is made of horniness aluminum alloy, pass through anodic oxidation treatment and polyester powder coating, so it has strong corrosion resistance. Protection grade is IP67, NEMA4 and 6, and optional IP68 type.
- 电机**--全封闭式鼠笼式电机，体积小，扭矩大，惯性力小，绝缘等级为F级，内置热保护开关，可防止损坏电机。
Electric Machinery--Fully enclosed Squirrel-cage electric Machinery, small volume, large torque, and small inertia force, F-class insulation rating, inside hot protection switch, avoid damaging the electric machinery.
- 手动结构**--手柄的设计保证安全可靠、省力、体积小。不通电时，扳动手柄可进行手动操作。不用手动时，将扳手置于扳手夹内，方便使用。
Manual Structure--The design of handle ensure safe, reliable, labor-saving, small volume. When it don't have electricity, it can be manually operated by handle. When you don't operate by manus, you can put the wrench in the wrench folder, then you can easy to use it.
- 指示器**--指示器安装在中心轴上，可以观察阀门位置。透镜采用凸出镜设计，不积水，观察更方便。
Indicator--Indicator installs in the center axis, so it can observe the valve position. It adopts convex mirror design, no cumulate water, more convenient to observe.
- 干燥器**--用来控制温度，防止由于温度和天气变化导致执行器内部水分凝结，保持内部电气元件的干燥。
Space Heater--It is used for control temperature, avoiding internal moisture of electric actuator condensed because of the changing of temperature and weather, keep inner electric device dry.
- 密封**--密封性好，标准产品防护等级是IP67，并可选IP68防护等级。
Sealing--Good sealing performance, and the protection class of standard product is IP67, and optional IP68 protection grade.
- 限位开关**--机械、电子双重限位。机械限位螺钉可调，安全可靠；电子限位开关由凸轮机构来控制，简单的调整机构能精确并方便地设定位置，且不受手轮过量的影响。
Limit switch--Mechanical, electronic double limit. Mechanical limit screw is adjustable, safe and reliable; electron limit switch is controlled by the cam mechanism, easy adjustment institutious can set the position accurately and conveniently, and it doesn't affect overly by handwheel.
- 自锁**--精密的蜗轮蜗杆机构可高效传输大扭矩，效率高，噪音低（最大50分贝），寿命长；有自锁功能，防止反转，传动部分稳定可靠，无需再加油。
Self-locking--Exact worm and worm gear can efficiently transfer large torque, high efficiency, low noise (max.50 dB), long life, and it has self-locking function to prevent the inversion, transmission part is stable and reliable, no need to add oil.
- 防脱螺栓**--拆除外壳时，螺栓附在壳体上，不会脱落。
Anti-off bolt--When removed the shell, the bolt would be attached to the shell and didn't fall off.
- 安装**--底部安装尺寸符合ISO5211/DIN3337国际标准，孔成双四方便于带方杆的阀线性或45°转角安装，适应性强。可以垂直安装，也可以水平安装。
Install--The installation size of the bottom conforms to the international standard ISO5211/DIN3337, The holes are double square so that it's easy to fix the linear or 45° corner valves attached square bar, adaptable. It can be installed vertically, and also can be installed level.
- 线路**--控制线路符合单相或三相电源标准，线路布置紧凑合理，接线端子可有效满足各种附加功能的要求。
Circuitry--Control circuit conforms to the single-phase or three-phase power supply standard, reasonably compact line layout, wiring terminals can effectively satisfy a variety of additional functional requirements.

性能参数 Performance Parameter

型号 Model	最大输出扭矩 Max output torque N · m	动作时间90° Operating time (S)	输出轴 Output axis(mm)				电机(W) Electrical machinery	单相额定电流 Single-phase rated current 220V(A) 50HZ	重量 Weight (Kg)
			方Square	深Deep	圆 Round	深Deep			
ODL-003	30	10	9×9	13.5	Φ12.6	26	8	0.15	2.1
			11×11	15.5					
ODL-005	50	30	11×11	15.5	Φ12.6	26	10	0.25	3.6
			14×14	18					
ODL-008	80	30	11×11	15.5	Φ15.7	26	10	0.25	3.6
			14×14	18					
ODL-010	100	30	14×14	18	Φ15.78	28	15	0.35	4.6
			17×17	22.5	Φ18.95	28			
ODL-015	150	30	14×14	18	Φ18.95	28	15	0.37	4.6
			17×17	22.5					
ODL-020	200	30	22×22	26	Φ22.13	45	45	0.3	13
ODL-030	300	30	22×22	26	Φ28.48	45	45	0.31	13.4
ODL-040	400	30	22×22	26	Φ28.48	45	60	0.33	13.8
ODL-060	600	30	27×27	32.5	Φ31.65	45	90	0.33	14
ODL-080	800	45	27×27	32.5	Φ31.65	45	180	0.47	14.3
ODL-100	1000	135	27×27	32.5	Φ31.65	45	180	0.47	60
ODL-160	1600	135	Max Φ65		深65		180	0.85	60
ODL-200	2000	135	Max Φ65		深65		180	0.85	60
ODL-300	3000	135	Max Φ65		深65		180	0.85	60

标准技术参数 Standard Technical Parameter

外壳Shell	铝合金外壳, 防水级别: IP67, NEMA4 and 6 Aluminium alloy Shell, waterproof leve: IP67, NEMA4 and 6	
电机电源 Power supply	110/220V AC 1Phase, 380/440V AC 3Phase, 50/60Hz, ± 10%	
控制电源 Control supply	110/220V AC 1Phase, 50/60 Hz, ± 10%	
电机 Electric machinery	鼠笼式异步电动机 Squirrel-cage Asynchronous electric Machinery	
限位开关 Limit switch	2 × 开 (On) / 关 (Off), SPDT, 250V AC 10A	
辅助限位开关 Accessorial Limit switch	2 × 开 (On) / 关 (Off), SPDT, 250V AC 10A	
行程 Stroke	90° ~ 270 ± 10° (90° 以上提前说明) When it's over 90° , please note us in advance	0° ~ 270
失效保护/操作温度 Speed protection/Operating temperature	内置热保护, 开 120°C ± 5°C / 关 97°C ± 15°C Inside hot protection, On 120°C ± 5°C / Off 97°C ± 15°C	
指示器 Indicator	连续的位置指示 Continuous situation indication	
手动操作 Manul operation	机械手柄 Mechanical handle (可选装手轮 Optional: fixing with the handwheel)	
自锁装置 Self-locking device	蜗轮, 蜗杆机构提供自锁 Provide self-locking by worm and worm gear	
机械限位 Mechanical Limit	2个外部调整螺栓 2 pieces of adjustable bolts	
干燥器 Space heater	7-10W (110/220V AC) 防冷凝 Condensation-preventing	
接线孔 Bonding hole	2个 (Pieces) M18	
环境温度 Ambient temperature	-20°C ~ +70°C	
润滑 Lubrication	铝基润滑脂 (EP型) Aluminium base grease (EP)	
材料 Material	钢, 铝合金, 铝青铜, 聚碳酸酯 Steel, Aluminium alloy, Aluminium bronze, Polycarbonate	
环境湿度 Ambient humidity	最大 (Max) 90% RH	非凝结 Non-Condensed
抗震性能 Shock survial	X Y Z 10g, 0.2-34 Hz, 30分 (minutes)	
外涂层 External coating	干粉, 环氧树脂 Dry powder, Epoxy polyester	

TANA



»»» **ODL 电动执行器系列**
ODL Series Electric Actuator



外观图 Outside view

1. ODL-003外观及安装尺寸

ODL-003 Appearance and installation dimension



图1

2. ODL-005-008 外观及安装尺寸 (虚线部分为模拟量控制盒, 开关型无此尺寸)

ODL-005-008 Appearance and installation dimension (The part of broken line is used for analog quantity control box, On-off model don't have this size.)

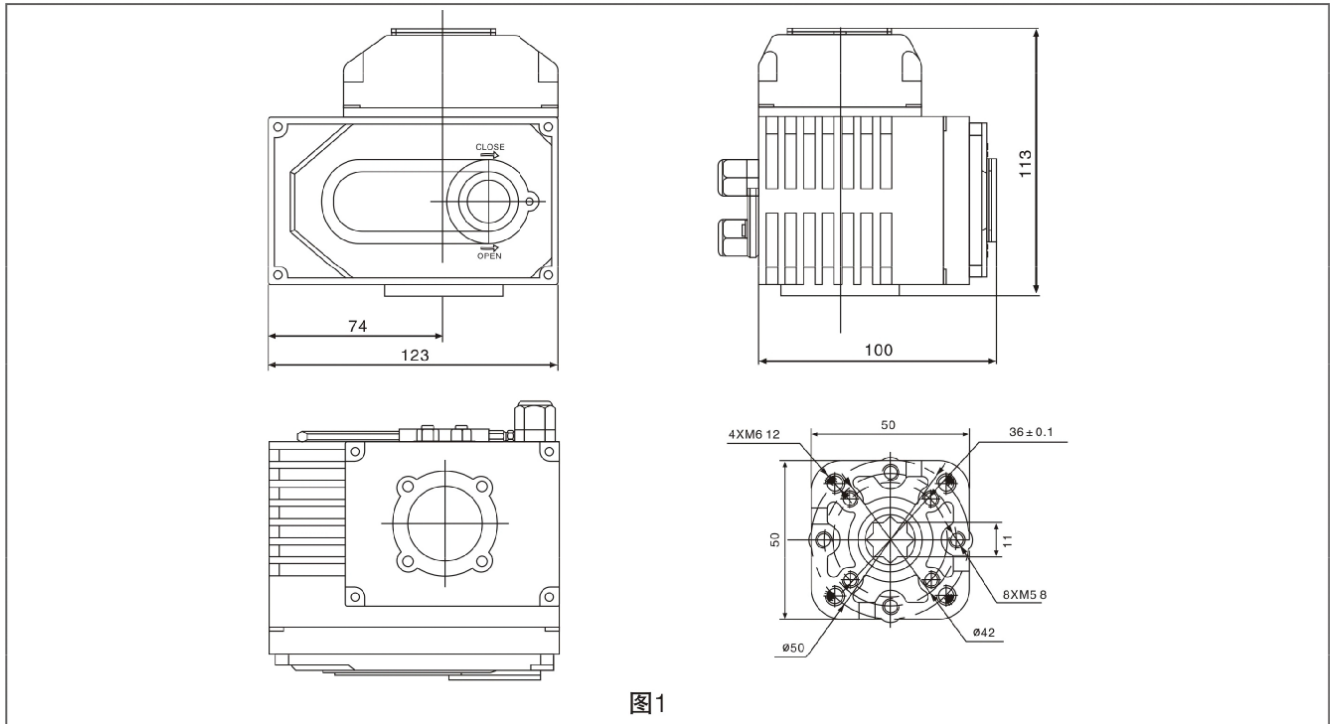

图2

3. ODL-010~015 外观及安装尺寸 (虚线部分为模拟量控制盒, 开关型无此尺寸)

ODL-010~015 Appearance and installation dimension (The part of broken line is used for analog quantity control box, On-off model don't have this size.)

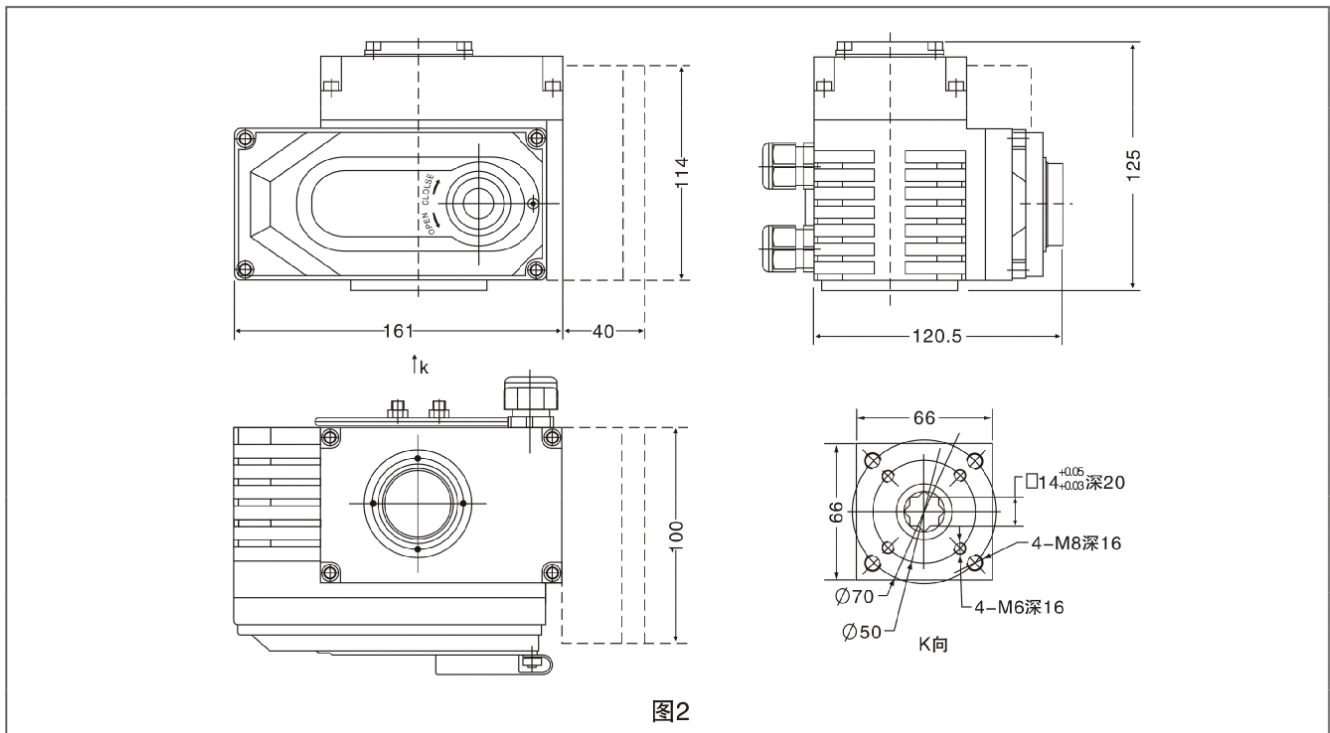

图3

4. ODL-020~080 外观及安装尺寸 (虚线部分为模拟量控制盒, 开关型无此尺寸)

ODL-20~80 Appearance and installation dimension (The part of broken line is used for analog quantity control box, On-off model don't have this size.)

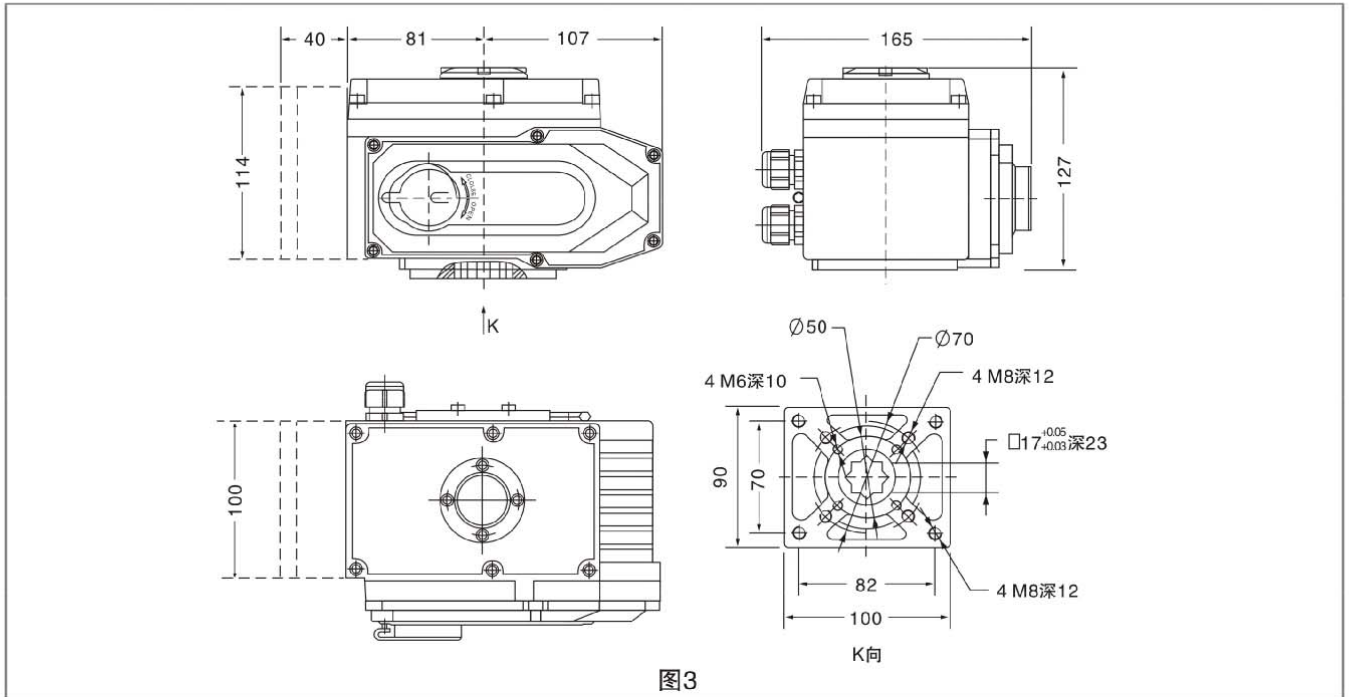

图4

5. ODL-100~300 外观及安装尺寸 (虚线部分为模拟量控制盒, 开关型无此尺寸)

ODL-100~300 Appearance and installation dimension (The part of broken line is used for analog quantity control box, On-off model don't have this size.)

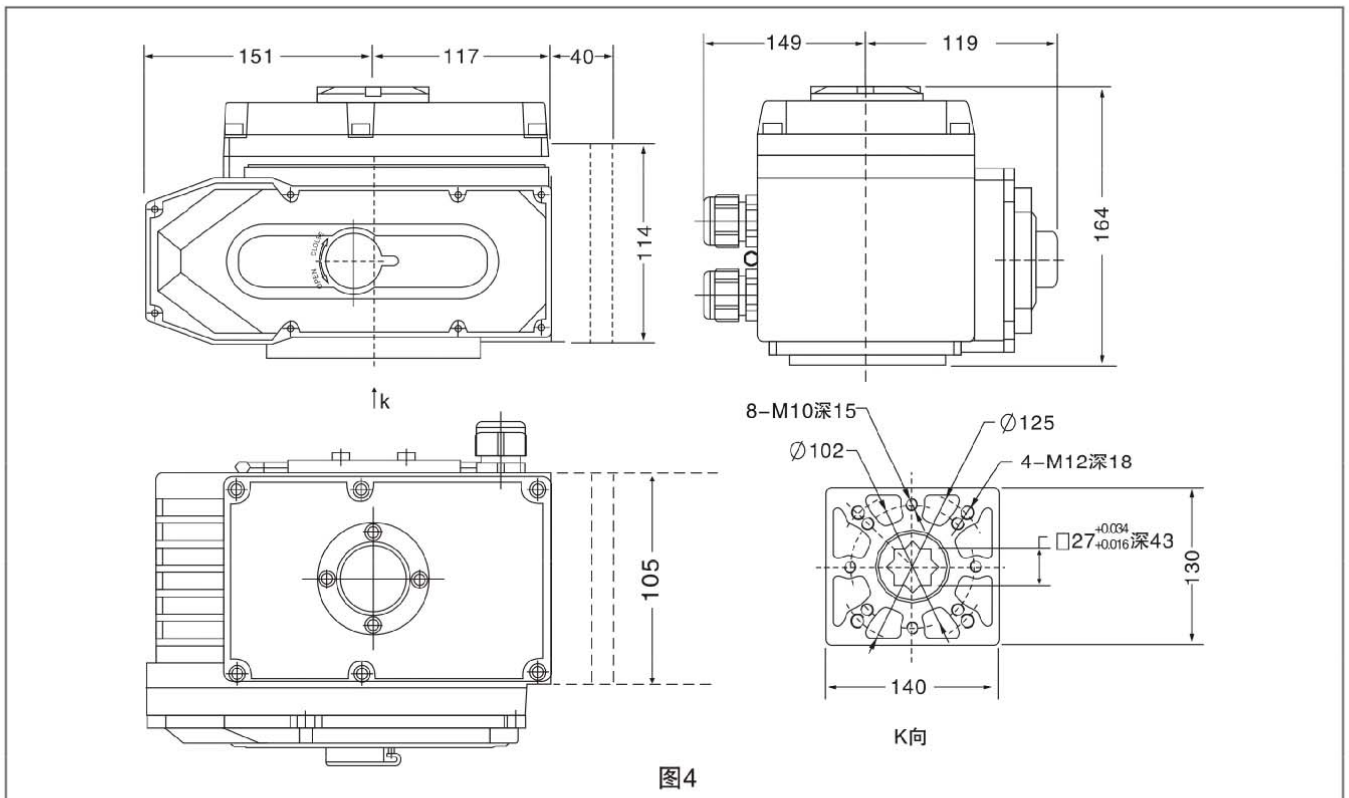
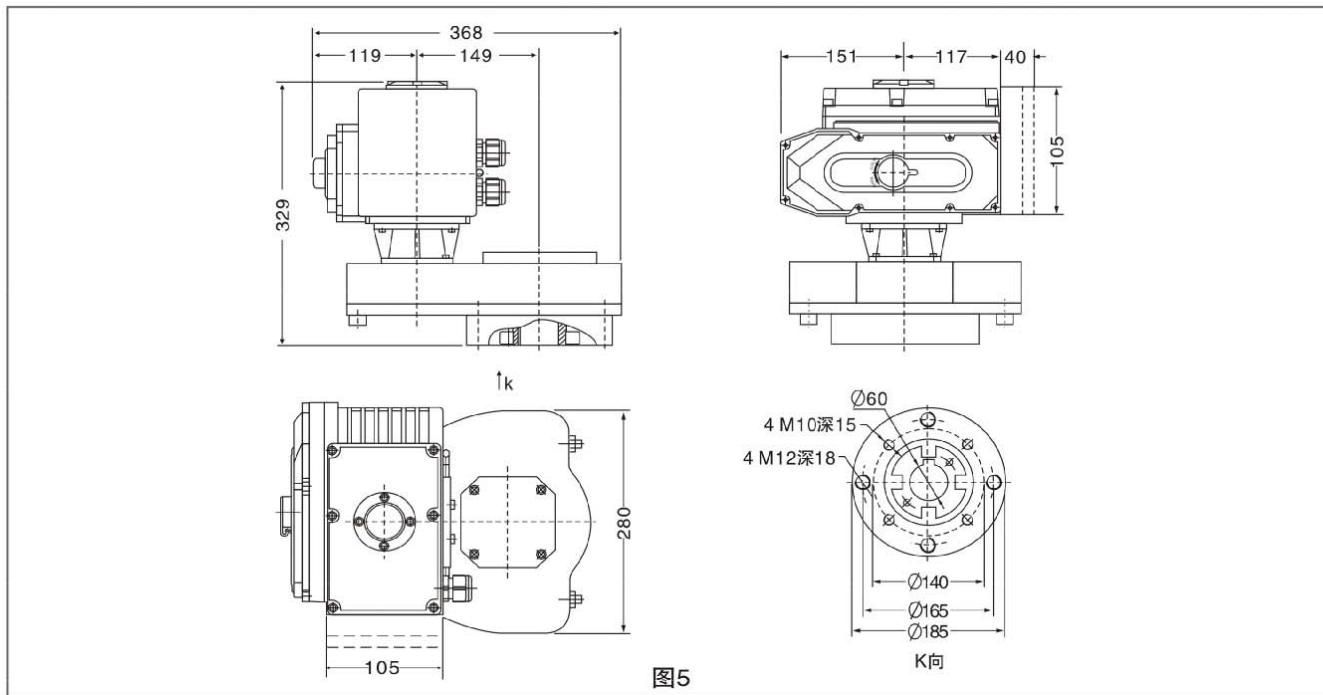

线路图 Circuit Diagram

1. 标准开关无源触点信号输出线路图

Standard on-off passive contact signal output circuitry

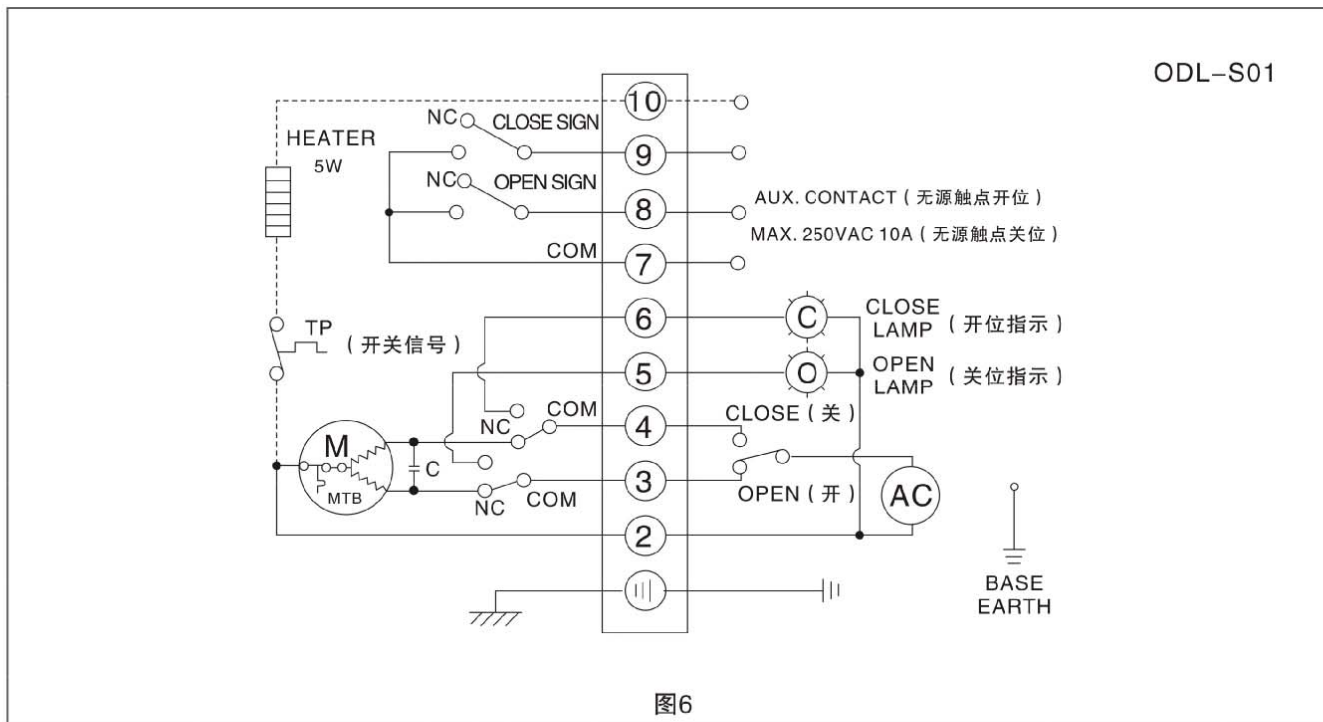

2. 模拟量无源触点信号输出线路图

Analog quantity passive contact signal output circuitry

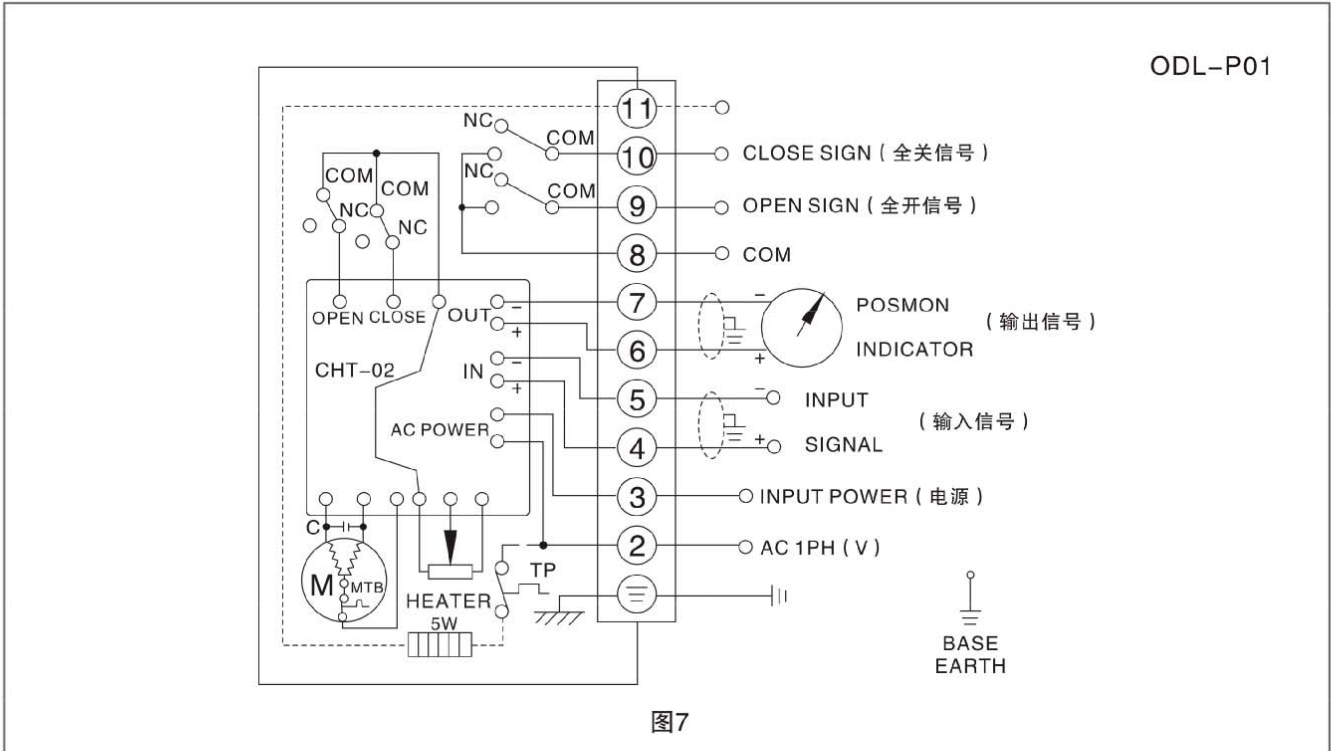

3. 角度及无源触点信号输出线路图

Angle and passive contact signal output circuitry

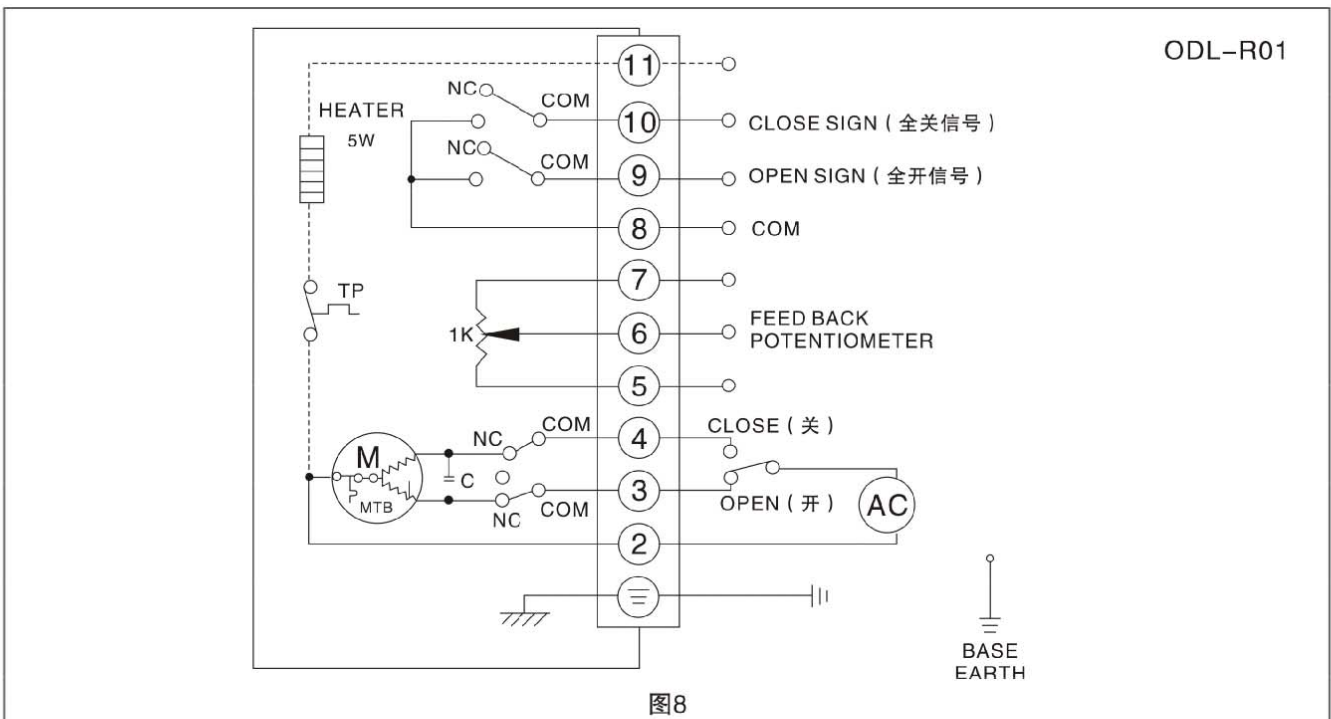

线路图 Circuit Diagram

4. 380/440VAC/50/60Hz,3相(外置控制开关型) 380/440VAC/50/60Hz,3Ph(Outer control On-off model)

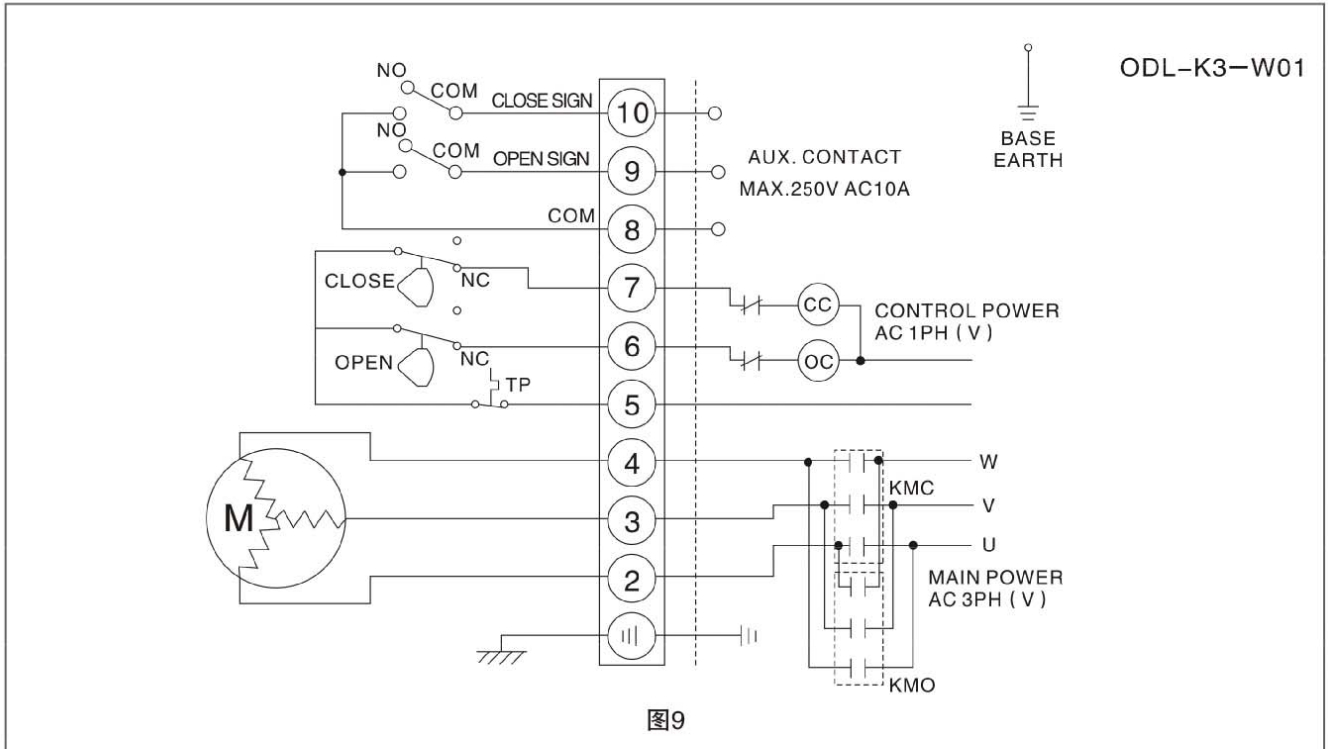

5. 开关量输入4~20mA信号及开关信号输出线路图 On-off input 4~20mA signal and open-closed signal output circuitry

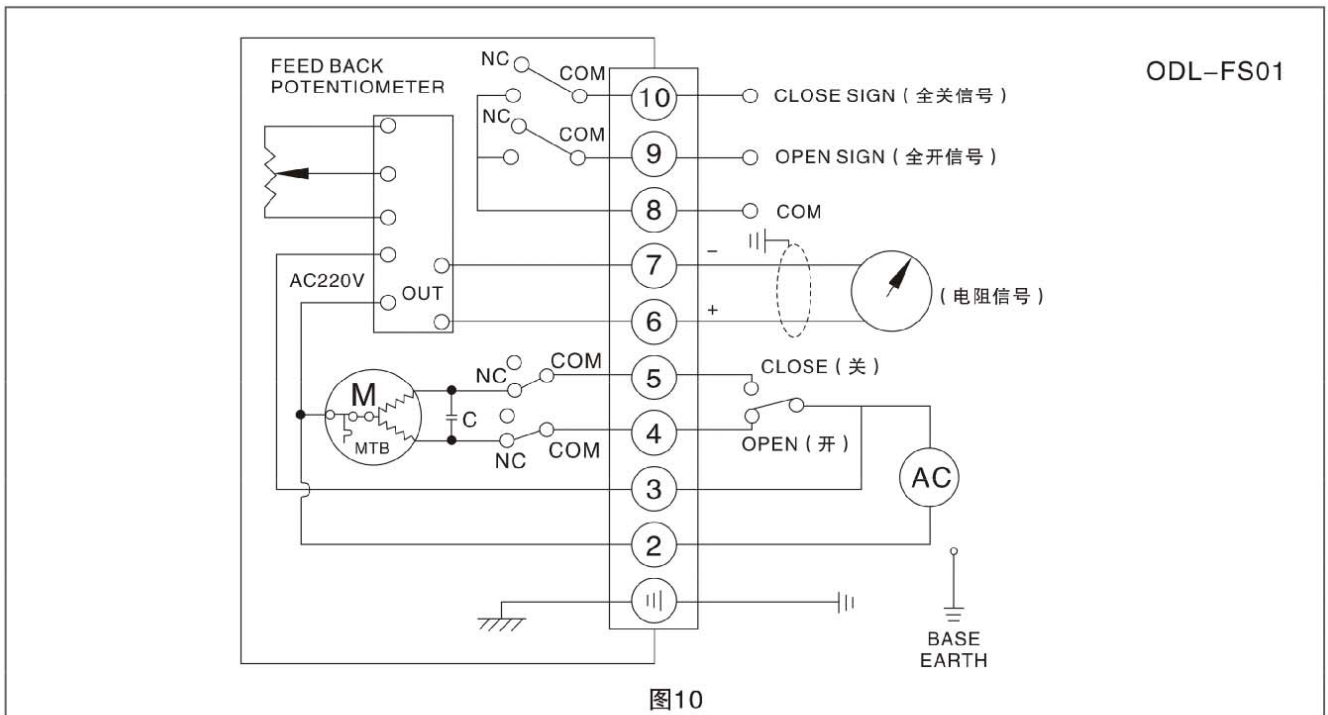

6. 直流标准开关无源触点信号输出线路图

DC standard on-off passive contact signal output circuitry

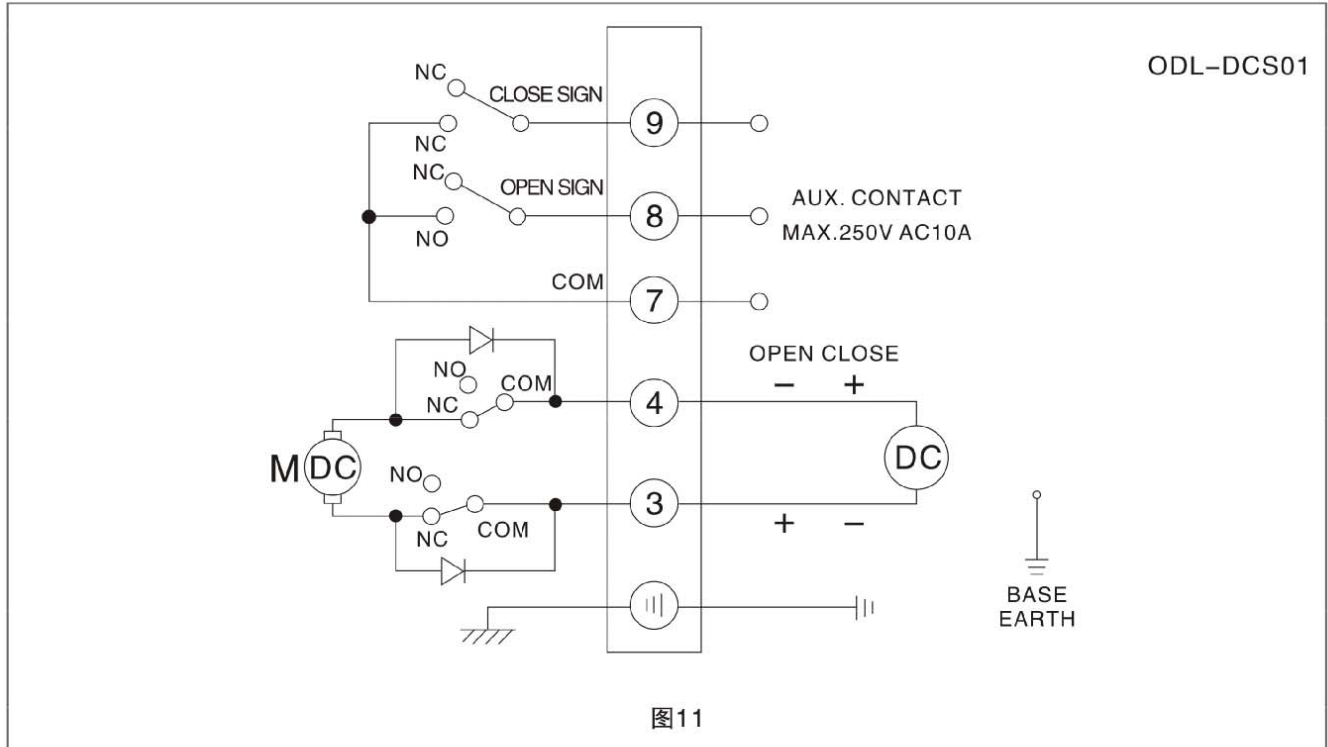

结构 Structure

电动执行器主要由以下几部分组成 Electric actuators is make up of the following parts:

- 壳体部分：包括外壳及底座部分；
Shell: including shell and pedestal
- 驱动部分：以高性能全封闭鼠笼式电机为动力源；
Drive parts: Full sealing high-performance squirrel-cage motor for the power source
- 传动机构：蜗轮与齿轮传动部分；
Driving mechanism: Worm and gear drive parts
- 比例控制部分：与机械部分分离，便于调试；
Ratio control parts: separate with the mechanical parts, easy to debug
- 限位开关部分；
Limit switch part
- 开度检测与反馈部分。
Opening Detected and Feedback Parts

执行器的安装 Installation of Electric actuators

1. 安装场所

1.1 室内安装的注意事项 Notes of interior installation

- 属非防爆产品，所以不要安装在有爆炸性气体的地方；
It's not a explosion-proof product, so that please don't install in the place of explosive gases;
- 安装在有水淹没及户外请提前说明；
When installing in the submerged or outdoor, please note us in advance;
- 请预留接线，手动操作等维修用空间。
Please reserve space for repairing cables, manual operation;

1.2 室外安装的注意事项 Notes of outdoor installation

- ⊙ 为了避免雨水，阳光直射等问题，需要安装保护盖，或选用防护等级 IP68

In order to avoid the rain, direct sunlight and so on, it needs to install a protective cover, or choose IP68 protection grade.

- ⊙ 请预留接线、手动操作等维修用空间。

Please reserve space for repairing cables, manual operation.

2. 环境温度、流体温度条件 The condition of Ambient temperature and Fluid temperature

2.1 环境温度 Ambient temperature

- ⊙ 环境温度在 -30°C ~ $+60^{\circ}\text{C}$

Ambient temperature at -30°C ~ $+60^{\circ}\text{C}$

- ⊙ 环境温度为零度以下时，在机内加装除湿加热器。

When ambient temperature is below zero, the machine needs to install space heater.

2.2 流体温度 Fluid temperature

- ⊙ 与阀门配套使用时，流体的热量会传到机体上面，机体温度会升高。流体温度属高温时，与阀门连接的支架要作特别处理

When using with the valve, the heat of the fluid will move to the body, then the body temperature will rise. When the fluid temperature is a high temperature, the bracket which is connecting with the valve need to make special treatment

- ⊙ 标准支架：流体温度 $+65^{\circ}\text{C}$ 以下使用标准支架或免支架

Standard bracket: when the fluid temperature is below $+65^{\circ}\text{C}$, it use standard bracket or no need to use bracket;

- ⊙ 中温支架：流体温度 $+65^{\circ}\text{C}$ 以上使用中温支架

Intermediate temperate bracket: when the fluid temperature is over $+65^{\circ}\text{C}$, it use intermediate temperate bracket;

- ⊙ 高温支架：流体温度 $+180^{\circ}\text{C}$ 以上使用高温支架

High-temperature bracket: when the fluid temperature is over $+180^{\circ}\text{C}$, it use high-temperature bracket.

3. 与阀门的连接 Connect with the valve

- ① 手动转动阀门，确认无异常情况，并转到全闭位置；

Turning valves by hand, confirmed that it didn't have abnormal situation, then turn to full-closed position;

- ② 将支架固定在阀门；

Fix the bracket on the valve;

- ③ 将电动装置放在支架上用螺栓和螺母轻轻拧上；

Put the electric actuator on the bracket, then screwing the bolts and nuts lightly;

- ④ 将电动装置转到关闭位置，用连轴器和螺钉将阀门芯轴和电动装置输出轴固定；

Put the electric actuator to the closed position, fixing valve mandrel and electric actuator with coupling and screw bolts;

- ⑤ 拧上电动装置和支架间的螺钉；

Screw the bolts between the electric actuator and the bracket;

- ⑥ 用手柄转动电动装置，确认无偏心、弯斜、运动平稳，注意不要超程！

Rotate the electric actuator by handle to confirm non-eccentric, curved ramps, smooth movement, and pay attention to not over travel!



图12

★ 注意事项：连轴器尽量减小回差

Note: Decrease hysteresis of the coupling as far as possible.

安装时，注意使执行器的开关与阀门的开关一致。执行器底部的法兰符合 ISO5211 标准，如果与之连接的阀门也符合此标准，则可方便连接；如不符合此标准，则需另加支架连接。

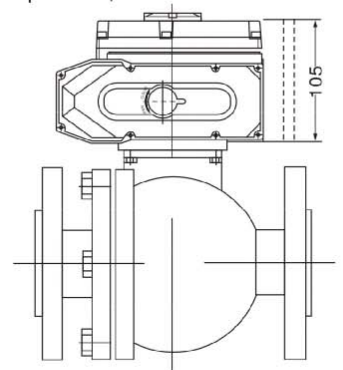
Pay attention to keeping the switch of electric actuator in line with the switch of the valve when installing. The flange of the electric actuator bottom conform to the standard ISO5211, if the valves which connect with the flange are also conform to this standard, it will be connect conveniently; if doesn't, it should be connecting with the bracket in addition.

调试说明 Debug Description

1. 行程限位的调整 (图13, 图14) Adjustment of stroke limit

转动手轮使执行器运动到阀门全关的位置。然后，用扳手松开限位凸轮固紧螺母，转动限位凸轮(黄色开，红色关)将其调整到恰好压下限位开关(CLS)的位置，再将限位凸轮螺母固紧。这样就设定好了执行器全关时行程限位的位置。全开时的位置同样方法设定。

Turn round handwheel making the electric actuator moved to the full-closed position. And loosen nuts on limit cam by spanner rotating limit cam (yellow open, red close) to adjusting just push down limit switch (CLS) position, and then screw limit cam nut. So, it's the way to set the full-closed stroke limit position of the electric actuator. Full-opened position is setting as the same way.



图13



图14

2. 机械限位的调整 Adjustment of mechanical limit

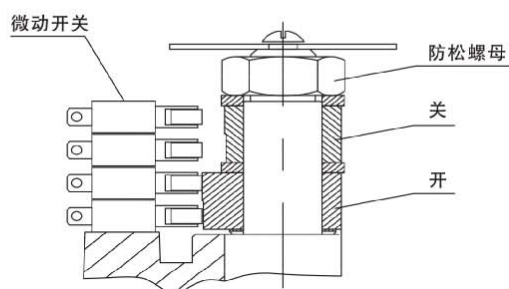
松开机械限位螺钉的锁紧螺母，然后手动使执行器运动到全关的位置，旋转限位螺母，当其碰到里面的扇形齿轮后停止转动，再旋出两圈，最后上紧锁紧螺母。这样就设定好了执行器全关时的机械限位的位置。全开时的位置可同样设定。如图15所示：

Loosen the nuts of the mechanical limit, and then move the electric actuator to the full-closed position by hand, rotating the limit nuts, stop rotating when it comes across inside the fan-shaped gear, and then circle out two circles, screw the nuts at last. So, it's the way to set the full-closed mechanical position of the electric actuator. Full-open position is setting as the same way. Follow as the picture 14:

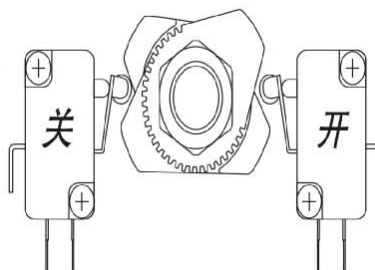

图15

3. 电位器的调整 Adjustment of potentiometer

电位器在执行器中作为一种反馈信号输出，有三个输出端子，其中②脚接电位器的滑臂。①脚接执行器开动作时，与滑臂之间的电阻不断减小一端，③脚则接执行器关闭动作时与滑臂之间的电阻不断减小一端（注意：电位器不应出现阻值过零，跳变现象）。用手柄转动阀门到全开位置，以开到限位开关动作为准，用万用表测量，将接线端子上②脚①脚电阻调整到 $35\Omega - 60\Omega$ 之间。若不正确可通过转动电位器传动齿轮调整。

Potentiometer is used for exporting feedback signal in the actuators, it exports 3 pieces of terminals, thereinto ② side connect with slide arm of potentiometer (refer to picture 16). ① side connect with the terminal which resistance between slide arms constantly decrease, when the actuator is opening movement, ③ side connect with the terminal which resistance between slide arms constantly decrease, when the actuator is closed movement. (Note: The potentiometer resistance should be not over-zero, jump phenomenon.) Rotating the valve to the wide-open position by handle, as per open to limit switch closed movement, measured with a multimeter to adjust the resistance between ② and ① side to $35\Omega - 60\Omega$. If it's not correctly, it can adjust through rotating drive gear of potentiometer.

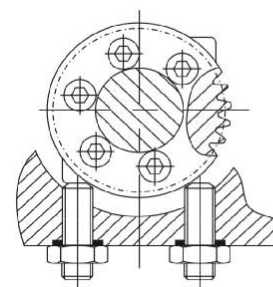

图16

调试说明 Debug Description

1. 手动操作 Manual Operation

进行手动操作时，必须先把电源切断；摘下减速盖的橡胶帽，将附带的手柄插入六角孔内；将手动手柄按顺时针方向转动使开度减少。

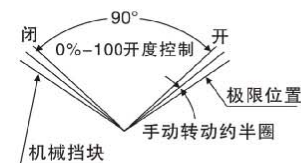
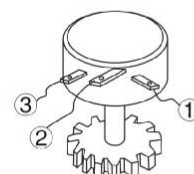
First of all, it should be cut off the power, when it's operating by hand; take off the rubber caps on the gear cover, put the accessory handle in the hexagonal hole; rotate the handle clockwise direction to reduce the opening.

★注意：开度转到全开、全团位置时，极限开关产生动作再转动半圈，会碰到机械挡块上，过分转动，会导致其它零件的损坏，因此要避免用力过大。

Note: Opening to the full-open or full closed position, limit switch turns half circle, it will come across mechanic block, if rotate excessively, it would result the damage of other parts, so it should be avoid excessive force.



图17

2. 电动操作 Electric operation

⊙电动操作之前，先用手动操作的方法，检查开度计和阀门角度（全开、全闭）是否一致；

Before electric operation, checking opening meters in line with the angle of valves by the methods of manual operation(full-open, full-closed);

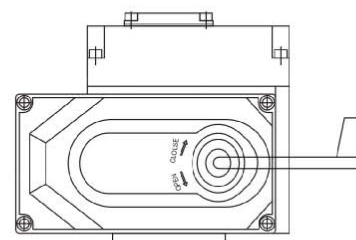
⊙检查接线是否正确，同时必需先用外部切换开关，确认开闭动作；

Check the wiring correct, at the same time need to use an external switch to confirm opening and closing movements;

⊙确认以上状态之后，开始电动操作。

After confirm the over status, then start electric operation

3.注意 Note

①检查接线图，电源，输入/输出信号是否正确。

Check wiring diagram, power supply, input/output signal correctly.

②尽量不要改变内部接线。

Don't change the internal wiring.

③如果电源为3相，应检查旋转方向。

If the power supply is 3 phase, it should be checking the rotating direction.

④手动使执行机构处于半开/关位，通电并输入开信号。

Enable the electric actuator lies in a half on/ff position, turn on electricity and input the open signal.

⑤如果执行机构向开位运行，则说明接线正确。

If the electric actuator runs to the open position it means the wiring is correct.

⑥如果运动方向相反，则必须交换3根电源线中的两根。

If the running direction is opposite, it must be change 2 pieces wiring in 3 pieces of wiring.

保养 Maintenance

加油：由于使用寿命长，耐压性好的特殊钼基润滑脂，所以不需加油；

Oiling: Because of using the long life, good pressure resistance of special Mo-based grease, so it doesn't need to add the oil.

定期运转：在阀门的动作很稀少时，可以定期驱动机器，检查在无异常。

Regular operation: When the valve works infrequently, it should be driven the machine regularly, checking abnormality or not.

★注：模拟量调节型调试说明请参阅执行器控制模块部分说明书。

Note: Debugging description of analog volume adjustment type, please refer to the specification of the actuator control module part.

其他个性化功能 电动执行器 Other personalized features electric actuators

⊙阀门全开、全关动作时间2.8秒到8秒(可选)，用于一些需快速动作的工况；

The time of the valve move to full-open or full-closed only need 2.8s-8s(optional), it's used for some working condition which need to move quickly.

⊙水下短时间工作，用于一些有时电动执行器被水浸没的工况；

Working under the water in short time, it's used for some working condition which the electric actuator is immersed in the water sometimes.

⊙阀门全开、全关特别缓慢，执行器可使阀门旋转90° 动作时间达到650秒；

The valve move to full-open or full-closed slowly in particular, the actuator is enable to rotating the valve 90° achieve 650 s.

⊙手动操作可采用带离合手轮机构；

Manual operation adopts handwheel with clutch.

⊙具有现场，就地/远程切换功能；

It's provided with the scene, local/remote switching function

⊙有DC 12V, DC 24V, DC 110V, DC 220V; AC 24V, AC 110V, AC 380V, 可订做；

It's provided with DC 12V, DC 24V, DC 110V, DC 220V; AC 24V, AC 110V, AC 380V;

★注：其他不详或特殊规格，请与本公司技术部联系。

Note: Other unknown or special specifications, please contact with Technology Department of our company.