

■ **General**

Trunnion mounted ball valves are designed in accordance with API 6D for classes ASME Class 150,300,600,900,1500,and 2500, Two-piece split body cast steel and Three-piece forged steel side entry design bolted connections between body and closure, trunnion bolted connection, body thickness comply with ANSI B16.34. Seat ring is floating type, springloaded to assure the contact with ball in order to provide an effective tight seal even at low differential pressure between cavity and downstream closure. Standard design is soft seated, A different soft seat materials are available based on the customer working condition. Available in Full and Reduced Bore. Electrical, pneumatic and hydraulic actuators are available based on customer requirement. Valves have been designed for use with various combinations of materials such as: Carbon Steel, Low Carbon steel, special alloy, stainless steel, Monel, Inconel.

■ **Stem Design/Anti Blowout**

The stem is made separately from the ball, anti blow-up design with suitable PTFE and graphite rings, See Fig 1

■ **Anti-Static Device**

All flow control-floating flange ball valves include dual grounding systems from stem to ball and stem to body. Valve testing to BS 5351 and BS 5146 was performed for all sizes, and witnessed by a third party inspection company. See fig.1

■ **Emergency sealant injection**

Trunnion type ball valves are fitted with emergency seals to restore sealing in case of soft seal damage. see fig.1 and fig.2

■ **Double Block and Bleed**

Ball valves can be equipped with drain valve which allows the block and bleed feature when the pressure is simultaneously applied to both sides of the ball, the medium can be relieved through the drain valve. Standard design of trunnion mounted ball valves assure that each seat ring performs the "single piston action"

■ **Body Joint Construction**

Three pieces body end entry design, graphite ring or o-ring viton (or request) seal ensure absolute seal integrity. The bolted body designs include a tight tolerance overlapping metal fit between the body and the adapter to minimize any possibility of movement due to pipeline stress, High temperature spiral wound stainless steel/graphite filled gasket is used for absolute seal. Body and adaptors are dimensioned for metal contact to ensure correct gasket crush.

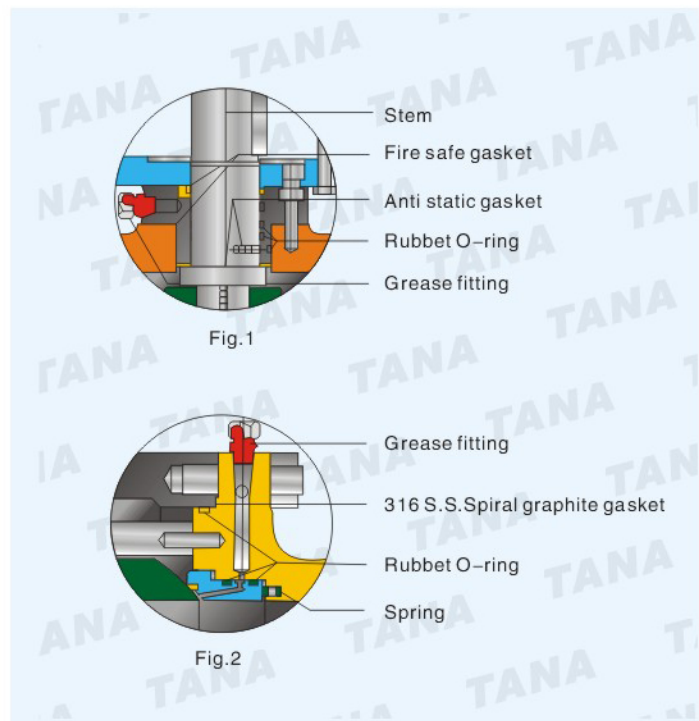
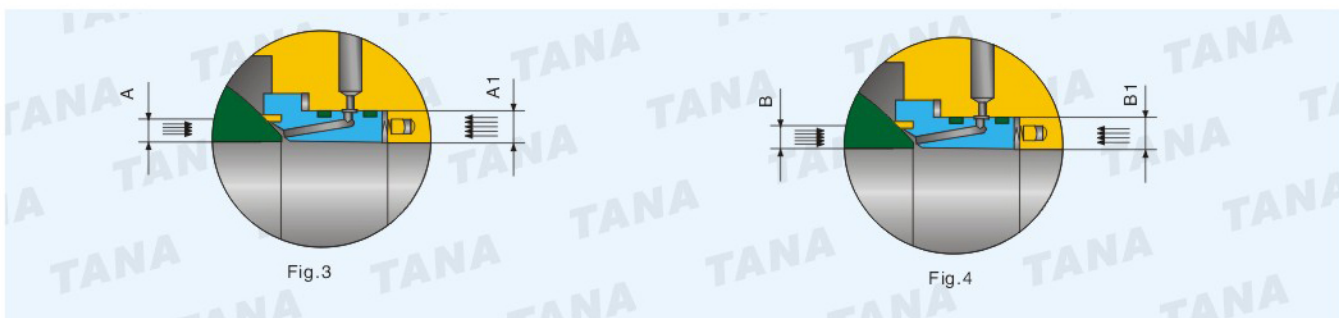

Fig.3 shows pressure A<A1. the contact between ball and seat ring assured. Fig.4 shows pressure B>B1. the self relieving action allows that valve seat will move slightly away from the ball surface, so any over pressure acting in the body cavity is discharged on the line to restore the balance between the body cavity and line



**Top Flange**

Top flange surface are machined and drilled, ready for mounting actuator.

**Fire Safe**

All fire-safe valves conform to API 607 and API 6FA standards.

■ **Features Two-piece body**

Valve is designed in accordance with the requirements of API 6D for pipeline service. Antistatic and anti blow-out stem design. Seat design gives perfect tightness and is available as either self-relieving type or double piston effect type. Design minimizes friction leading to low operating torque. Available as double block and bleed device, which allows for venting and draining of line fluid from the body cavity. Full and Reduced bore Available. Ball valves fire safe tested according to BS EN 12266-2, API 6FA and API 607. Electric, pneumatic and hydraulic actuators are available based on customer's requirement.

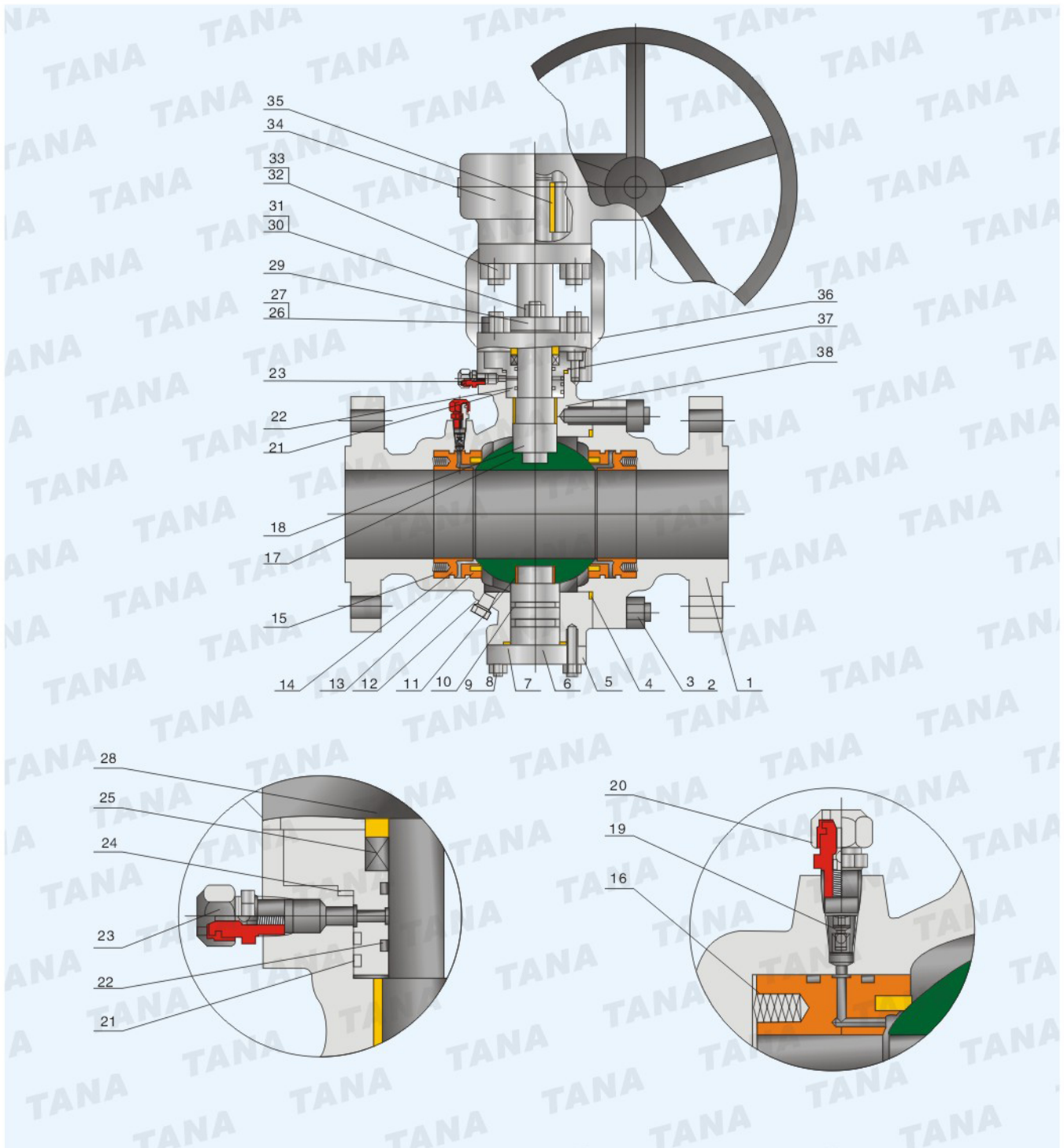



■ **Material Specifications**

No	Parts	Standard	Stainless Steel	Sour Service	Low Temperature Service
1	Body	ASTM A216 WCB	ASTM A351 CF8M	ASTM A216 WCB	ASTM A352 LCB
2	Body stud	ASTM A193 B7	ASTM A193 B8	ASTM A193 B7M	ASTM A320 L7M
3	Body Nut	ASTM A194 2H	ASTM A194 8	ASTM A194 2HM	ASTM A194 7M
4	Body Gasket	316ss+Graphite	316ss+Graphite	316ss+Graphite	316ss+Graphite
5	Low Cver	Carbon Steel	S.S.	Carbon Steel	Carbon Steel
6	Trunnion Support	ASTM A216 WCB/ENP	ASTM A216 WCB/ENP	ASTM A216 WCB/ENP	ASTM A216 WCB/ENP
7	Thrust Washer	316+PTFE+MoS2	316+PTFE+MoS2	316+PTFE+MoS2	316+PTFE+MoS2
8	Stud	ASTM A193 B7	ASTM A193 B8	ASTM A193 B7M	ASTM A320 L7M
9	Nut	ASTM A194 2H	ASTM A194 8	ASTM A194 2HM	ASTM A194 2M
10	O-Ring	NBR	NBR	NBR	NBR
11	Bering	316+PTFE+MoS2	316+PTFE+MoS2	316+PTFE+MoS2	316+PTFE+MoS2
12	Drain Plug	Assembly	Assembly	Assembly	Assembly
13	Seat Insert	25% Glass-filled PTFE	25% Glass-filled PTFE	25% Glass-filled PTFE	25% Glass-filled PTFE
14	O-Ring	NBR	NBR	NBR	NBR
15	Seat Spring	ASTM A105/ENP	ASTM A182 F316	ASTM A105/ENP	ASTM A350 LF2/ENP
16	Seat Spring	Inconel X-750	Inconel X-750	Inconel X-750	Inconel X-750
17	Ball	ASTM A 105/ENP	ASTM A182 F316	ASTM A105/ENP	ASTM A350 LF2/ENP
18	Stem	ASTM A182 F316	ASTM A182 F316	ASTM A182 F316	ASTM A182 F316
19	Seat Injection	Assembly	Assembly	Assembly	Assembly
20	Sealant Fitting	Assembly	Assembly	Assembly	Assembly
21	O-Ring	NBR	NBR	NBR	NBR
22	O-Ring	NBR	NBR	NBR	NBR
23	Sealant Fitting	Assembly	Assembly	Assembly	Assembly
24	Gasket	316ss+Graphite	316ss+Graphite	316ss+Graphite	316ss+Graphite
25	Packing	Graphite	Graphite	Graphite	Graphite
26	Stud	ASTM A193 B7	ASTM A193 B8	ASTM A193 B7M	ASTM A320 L7M
27	Nut	ASTM A194 2H	ASTM A194 8	ASTM A194 2HM	ASTM A194 7M
28	Gland	ASTM A182 F316	ASTM A182 F316	ASTM A182 F316	ASTM A182 F316
29	Gland Flange	ASTM A216 WCB	ASTM A351 CF8M	ASTM A216 WCB	ASTM A352 LCB
30	Stud	ASTM A193 B7	ASTM A193 B8	ASTM A193 B7M	ASTM A320 L7M
31	Nut	ASTM A 194 2H	ASTM A 194 8	ASTM A 194 2HM	ASTM A 194 7M
32	Stud	ASTM A193 B7	ASTM A193 B8	ASTM A193 B7M	ASTM A320 L7M
33	Nut	ASTM A194 2H	ASTM A194 8	ASTM A194 2HM	ASTM A194 7M
34	Worm	Assembly	Assembly	Assembly	Assembly
35	Key	Carbon Steel	S.S.	Carbon Steel	ASTM A182 F304
36	Yoke	ASTM A216 WCB	ASTM A351 CF8M	ASTM A216 WCB	ASTM A352 LCB
37	Bolt	Carbon Steel	S.S.	Carbon Steel	Carbon Steel
38	Bearing	316+PTFE+MoS2	316+PTFE+MoS2	316+PTFE+MoS2	316+PTFE+MoS2

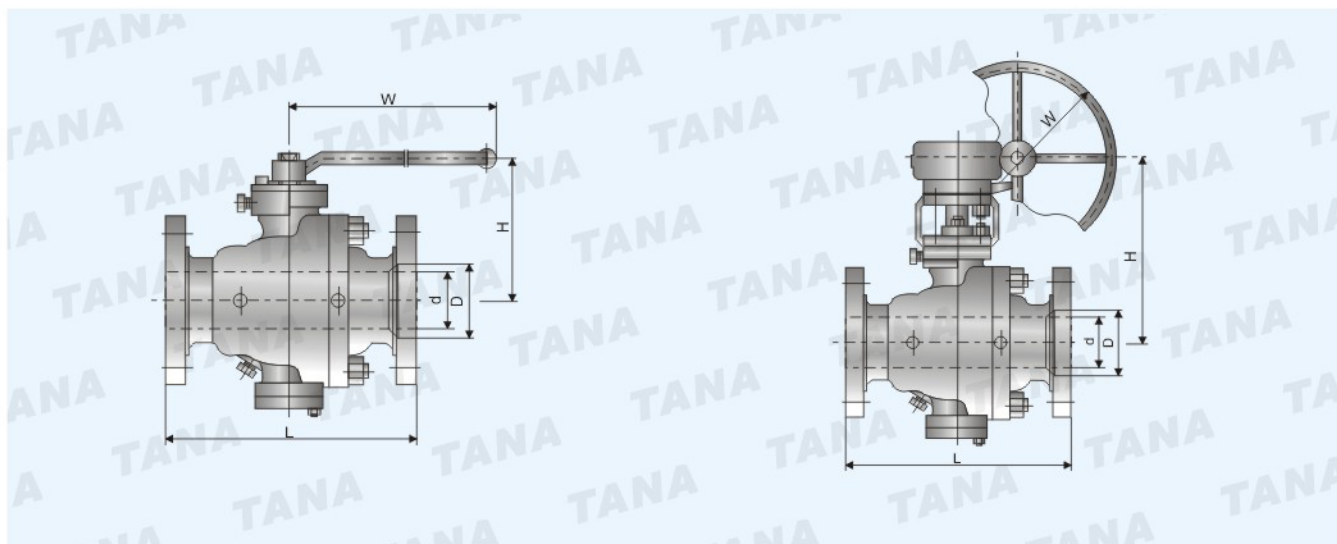

■ **Full bore(Class 150/10K)**

Size(in.)	D(mm)	L(mm)	H(mm)	W(mm)	WT(kg)
2	51	178	165	230	17
3	76	203	193	400	33
4	102	229	231	460	50
6	152	394	390	1000	93
8	203	457	495	*500	166
10	254	533	505	*500	273
12	305	610	560	*500	475
14	337	686	600	*500	570
16	387	762	750	*500	778
18	438	864	845	*500	935
20	489	914	910	*500	1190
22	540		1000	*500	1346
24	591	1067	1065	*500	1579

■ **Reduce bore(Class 150/10K)**

Size(in)	d(mm)	D(mm)	L(mm)	H(mm)	W(mm)	WT(kg)
3 × 2 × 3	51	76	203	165	230	30
4 × 3 × 4	76	102	229	193	400	47
6 × 4 × 6	102	152	394	231	400	90
8 × 6 × 8	152	203	457	390	460	161
10 × 8 × 10	203	254	533	495	1000	268
12 × 10 × 12	254	305	610	505	*500	467
14 × 12 × 14	305	337	686	560	*500	560
16 × 14 × 16	337	387	762	600	*500	766
18 × 16 × 18	387	438	864	750	*500	902
20 × 18 × 20	438	489	914	845	*500	1130
22 × 20 × 22	489	540	1016	910	*500	1300
24 × 22 × 24	540	591	1067	1000	*500	1520

■ **Full bore(Class 300/20K)**

Size(in.)	D(mm)	L(mm)	H(mm)	W(mm)	WT(kg)
2	51	216	165	230	18
3	76	283	193	400	40
4	102	305	231	750	63
6	152	403	390	1000	150
8	203	502	495	1500	240
10	254	568	505	*500	305
12	305	648	560	*500	507
14	337	762	600	*500	602
16	387	838	750	*500	1000
18	438	914	845	*500	1160
20	489	991	910	*500	1320
22	540	1092	1000	*500	1540
24	591	1143	1065	*500	1874

■ **Reduce bore(Class 300/20K)**

Size(in)	d(mm)	D(mm)	L(mm)	H(mm)	W(mm)	WT(kg)
3 × 2 × 3	51	76	283	165	230	38
4 × 3 × 4	76	102	305	193	400	60
6 × 4 × 6	102	152	403	231	750	147
8 × 6 × 8	152	203	502	390	1000	234
10 × 8 × 10	203	254	568	495	1500	295
12 × 10 × 12	254	305	648	505	*500	488
14 × 12 × 14	305	337	762	560	*500	570
16 × 14 × 16	337	387	838	600	*500	910
18 × 16 × 18	387	438	914	750	*500	1020
20 × 18 × 20	438	489	991	845	*500	1280
22 × 20 × 22	489	540	1092	910	*500	1360
24 × 22 × 24	540	591	1143	1000	*500	1670



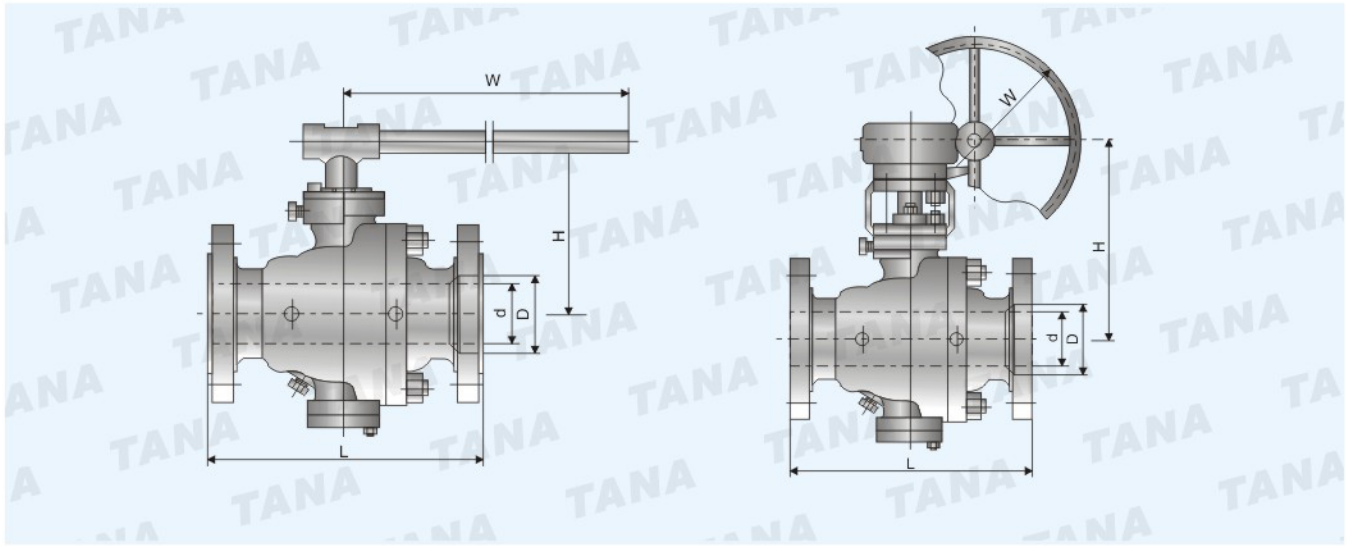

■ Full bore(Class 600)

Size(in.)	D(mm)	L(mm)	H(mm)	W(mm)	WT(kg)
2	51	292	176	400	27
3	76	356	247	750	50
4	102	432	335	1000	80
6	152	559	420	1500	220
8	203	660	430	*500	350
10	254	787	520	*500	600
12	305	838	665	*500	820
14	337	889	720	*500	1130
16	387	991	780	*500	1550
18	438	1092	950	*500	2100
20	489	1194	1010	*500	2800
24	591	1397	1120	*500	3626

■ Reduce bore(Class 600)

Size(in)	d(mm)	D(mm)	L(mm)	H(mm)	W(mm)	WT(kg)
3×2×3	51	76	356	176	400	41
4×3×4	76	102	432	247	750	70
6×4×6	102	152	559	335	1000	122
8×6×8	152	203	660	420	1500	255
10×8×10	203	254	787	430	*500	440
12×10×12	254	305	838	520	*500	662
14×12×14	305	337	889	665	*500	1060
16×14×16	337	387	991	720	*500	1440
18×16×18	387	438	1092	780	*500	1860
20×18×20	438	489	1194	950	*500	2400
24×22×24	489	591	1397	1010	*500	3240

■ Full bore(Class 900)

Size(in.)	D(mm)	L(mm)	H(mm)	W(mm)	WT(kg)
2	51	368	192	460	52
3	76	381	279	1000	97
4	102	457	355	1500	138
6	152	610	385	*500	288
8	203	737	460	*500	448
10	254	838	600	*500	748
12	305	965	690	*500	1018
14	324	1029	785	*500	1398
16	275	1130	850	*500	1828
18	426	1219	915	*500	2328
20	473	1321	975	*610	2928
24	572	1549	1030	*610	4178

■ Reduce bore(Class 900)

Size(in)	d(mm)	D(mm)	L(mm)	H(mm)	W(mm)	WT(kg)
3×2×3	51	76	381	192	460	83
4×3×4	76	102	457	279	1000	103
6×4×6	102	152	610	355	1500	201
8×6×8	152	203	737	385	*500	348
10×8×10	203	254	838	460	*500	598
12×10×12	254	305	965	600	*500	788
14×12×14	305	324	1029	690	*500	1100
16×14×16	324	375	1130	785	*500	1420
18×16×18	375	426	1219	850	*500	1928
20×18×20	426	473	1321	915	*500	2428
24×22×24	473	572	1549	975	610	3578

■ Features Three-piece body

Valve is designed in accordance with the requirements of API 6D for pipeline service.  
 Antistatic and anti blow-out stem design.  
 Seat design gives perfect tightness and is available as either self-relieving type or double piston effect type.  
 Design minimizes friction leading to low operating torque.  
 Available as double block and bleed device, which allows for venting and draining of ling fluid from the body cavity.  
 Full and Reduced bore Available.  
 Ball valves fire safe tested according to BS EN 12266-2, API 6FA and API 607.  
 Electric, pneumatic and hydraulic actuators are available based on customer's requirement.

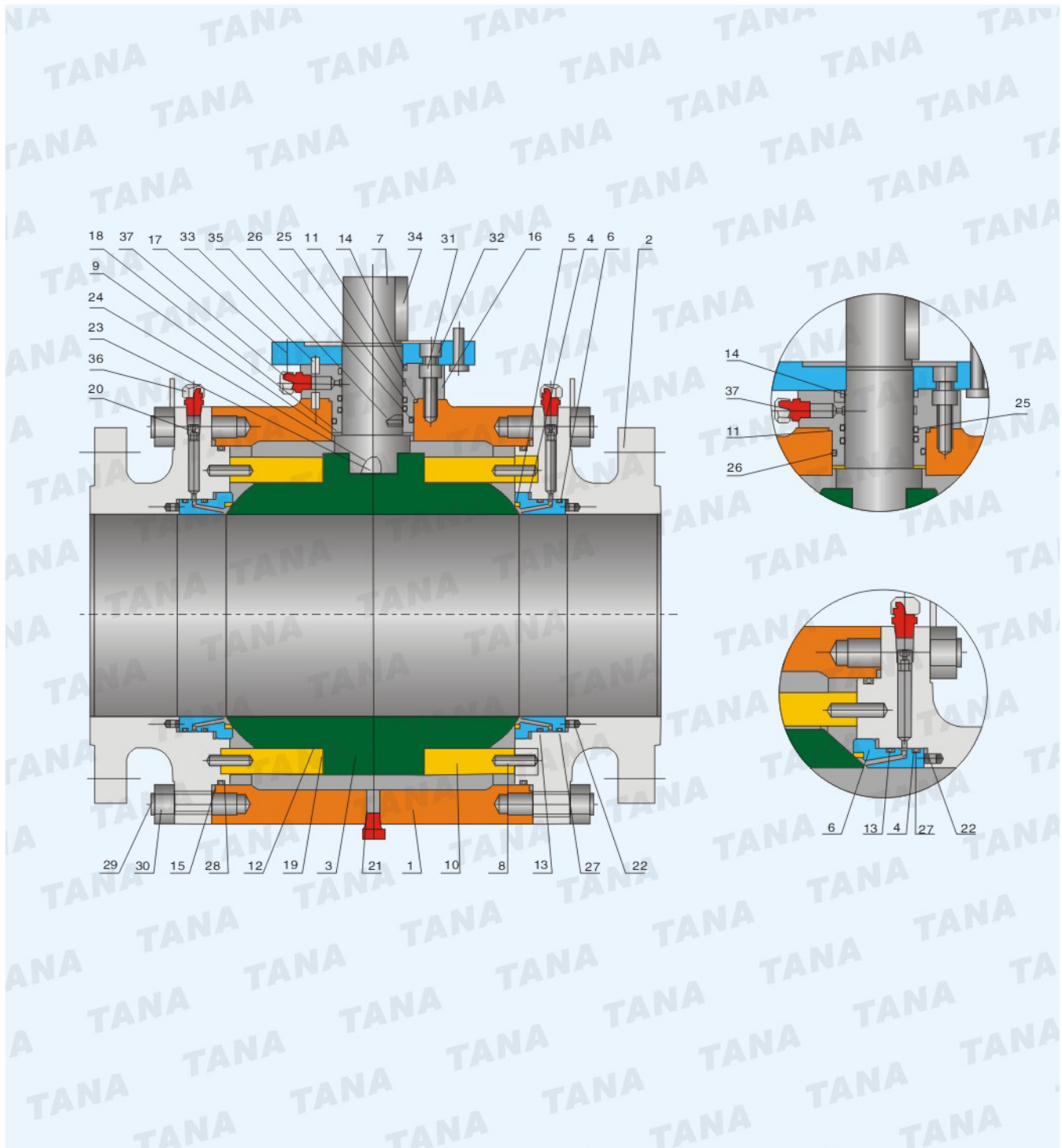



■ Material List

No	Parts	Standard	Stainless Steel	Sour Service	Low Temperature Service
1	Body	ASTM A105	ASTM A182 F316	ASTM A105	ASTM A350 LF2
2	Closure	ASTM A105	ASTM A182 F316	ASTM A105	ASTM A350 LF2
3	Ball	ASTM A105/ENP	ASTM A182 F316	ASTM A105/ENP	A350 LF2/ENP
4	Seat Assembly	Assembled	Assembly	Assembled	Assembled
5	Seat Insert	25% Glass-filled PTFE	25% Glass-filled PTFE	25% Glass-filled PTFE	25% Glass-filled PTFE
6	Seat Ring	ASTM A105/ENP	ASTM A182 F316	ASTM A105/ENP	A350 LF2/ENP
7	Stem	ASTM A182 F6a	ASTM A182 F316	ASTM A182 F316	ASTM A182 F316
8	Trunnion Alignment Pin	ASTM A182 F316	ASTM A182 F316	ASTM A182 F316	ASTM A182 F316
9	Shim	ASTM A182 F316	ASTM A182 F316	ASTM A182 F316	ASTM A182 F316
10	Trunnion Support	ASTM A105/ENP	ASTM A182 F316	ASTM A105/ENP	A350 LF2/ENP
11	Gasket	316 S.S.+Graphite	316 S.S.+Graphite	316 S.S.+Graphite	316 S.S.+Graphite
12	Gasket	316 S.S.+Graphite	316 S.S.+Graphite	316 S.S.+Graphite	316 S.S.+Graphite
13	Gasket	316 S.S.+Graphite	316 S.S.+Graphite	316 S.S.+Graphite	316 S.S.+Graphite
14	SPacer	PTFE	PTFE	PTFE	PTFE
15	Firesafe Gasket	316 S.S.+Graphite	316 S.S.+Graphite	316 S.S.+Graphite	316 S.S.+Graphite
16	Gland Cap	ASTM A 105	ASTM A 182 F316	ASTM A 105	ASTM A 350 LF2
17	Top Flange	ASTM A 105	ASTM A 182 F316	ASTM A 105	ASTM A 350 LF2
18	Thrust Washer	316 S.S.+PTFE+MoS2	316 S.S.+PTFE+MoS2	316 S.S.+PTFE+MoS2	316 S.S.+PTFE+MoS2
19	Bearing	316 S.S.+PTFE+MoS2	316 S.S.+PTFE+MoS2	316 S.S.+PTFE+MoS2	316 S.S.+PTFE+MoS2
20	Vent Valve	Assembly	Assembly	Assembly	Assembly
21	Drain	S.S.	S.S.	S.S.	S.S.
22	Seat Spring	Inconel X-750	Inconel X-750	Inconel X-750	Inconel X-750
23	Grounding Spring	S.S.	S.S.	S.S.	S.S.
24	Grounding Plunger	ASTM A 182 F316	ASTM A 182 F316	ASTM A 182 F316	ASTM A 182 F316
25	O-Ring	Viton	Viton	Viton	Viton
26	O-Ring	Viton	Viton	Viton	Viton
27	O-Ring	Viton	Viton	Viton	Viton
28	O-Ring	Viton	Viton	Viton	Viton
29	Body Stud	ASTM A193 B7	ASTM A193 B8	ASTM A193 B7M	ASTM A320 L7M
30	Body Nut	ASTM A194 2H	ASTM A194 8	ASTM A194 2HM	ASTM A194 7M
31	Screw	C.S.	S.S.	C.S.	ASTM A320 L7M
32	Screw	C.S.	S.S.	C.S.	ASTM A320 L7M
33	Gland Pin	C.S.	S.S.	C.S.	Carbon Steel
34	Key	C.S.	S.S.	C.S.	ASTM A182 L304
35	Spring Pin	C.S.	S.S.	C.S.	C.S.
36	Seat Injection	Assembly	Assembly	Assembly	Assembly
37	Stem Injection	Assembly	Assembly	Assembly	Assembly

**Class150/JIS10K Three-piece, split body, forged steel,  
Side entry design**

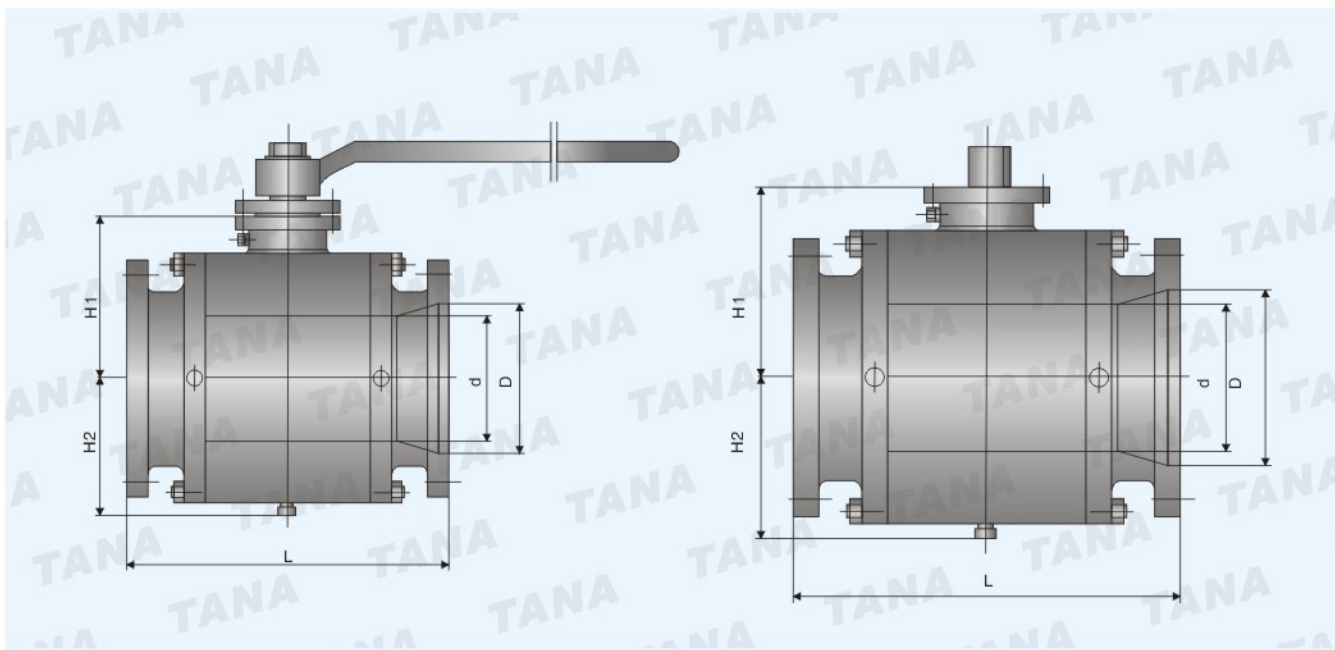

■ **Full Port(Class 150/10K)**

Size(in)	D(mm)	L(mm)	H1(mm)	H2(mm)	WT(kg)
2	51	178	105	100	32
3	76	203	160	130	53
4	102	229	205	170	100
6	152	394	245	190	157
8	203	457	280	230	250
10	254	533	326	250	390
12	305	610	350	300	578
14	337	686	380	330	770
16	387	762	415	350	1100
18	438	864	440	400	1250
20	489	914	500	440	1800
22	540	991	520	470	2400
24	591	1067	585	530	3100
26	635	1143	630	570	3700
28	686	1244	645	650	4500
30	736	1295	700	700	5300
32	781	1371	740	750	6900
34	832	1473	770	780	8200
36	876	1524	820	800	9700
40	978	1753	900	900	13000
42	1022	1855	960	950	15000
48	1168	2134	1100	1100	23000

■ **Reduced Port(Class 150/10K)**

Size(in)	d(mm)	D(mm)	L(mm)	H1(mm)	H2(mm)	WT(kg)
3×2×3	51	76	203	105	100	36
4×3×4	76	102	229	160	130	63
6×4×6	102	152	394	205	170	105
8×6×8	152	203	457	245	190	200
10×8×10	203	254	533	280	230	300
12×10×12	254	305	610	326	280	470
14×10×14	254	337	686	320	280	530
14×12×14	305	337	686	350	300	630
16×12×16	305	387	762	350	300	700
16×14×16	337	387	762	380	330	830
18×16×18	387	438	864	415	350	1100
20×16×20	387	489	914	415	350	1200
22×18×22	438	489	914	440	400	1300
24×20×24	489	591	1067	500	440	2100
30×24×30	635	736	1295	585	530	3400
36×30×36	781	876	1524	700	700	6400

■ **Notes**

1. Face-to-Face dimensions are according to API 6D
2. For 2" to 24" flanges are according to ASME B16.5
3. For over 24" .flanges are according to ASME B16.47 series A.



■ **Full Port(Class 300/20K)**

Size(in)	D(mm)	L(mm)	H1(mm)	H2(mm)	WT(kg)
2	51	216	105	100	31
3	76	282	160	130	58
4	102	305	205	170	110
6	152	403	245	190	180
8	203	502	280	230	280
10	254	568	326	250	410
12	305	648	350	300	760
14	337	762	380	330	1100
16	387	838	415	350	1600
18	438	914	440	400	1700
20	489	991	500	440	2300
22	540	1092	520	470	2900
24	591	1143	585	530	3500
26	635	1245	630	570	4900
28	686	1346	645	650	6000
30	736	1397	700	700	6800
32	781	1524	740	750	8000
34	832	1626	770	780	9100
36	876	1727	820	800	11000
40	978	1956	900	900	14000
42	1022	2083	960	950	17000
48	1168	2170	1100	1100	25000

■ **Reduced Port(Class 300/20K)**

Size(in)	d(mm)	D(mm)	L(mm)	H1(mm)	H2(mm)	WT(kg)
3×2×3	51	76	283	105	100	34
4×3×4	76	102	305	160	130	70
6×4×6	102	152	403	205	170	120
8×6×8	152	203	502	245	190	220
10×8×10	203	254	568	280	230	320
12×10×12	254	305	648	326	280	600
14×10×14	254	337	762	320	280	660
14×12×14	305	337	762	350	300	850
16×12×16	305	387	838	350	300	1000
16×14×16	337	387	838	380	330	1200
18×16×18	387	438	914	415	350	1700
20×16×20	387	489	991	415	350	1700
22×18×22	438	489	991	440	400	1850
24×20×24	489	591	1143	500	440	2700
30×24×30	591	736	1397	585	530	4600
36×30×36	736	876	1727	700	700	8000

■ **Notes**

- 1.Face-to-Face dimensions are according to API 6D
- 2.For 2"to 24" flanges are according to ASME B16.5
- 3.For over 24".flanges are according to ASME B16.47 series A.

■ **Full Port(Class 600)**

Size(in)	D(mm)	L(mm)	H1(mm)	H2(mm)	WT(kg)
2	51	292	105	100	35
3	76	356	160	130	66
4	102	432	205	170	118
6	152	559	245	190	270
8	203	660	280	230	500
10	254	787	326	280	780
12	305	838	350	300	1100
14	337	889	380	330	1100
16	387	991	415	350	1600
18	438	1092	440	400	2160
20	489	1194	500	440	2700
22	540	1296	520	470	3900
24	591	1397	585	530	5000
26	635	1448	630	570	5700
28	686	1549	645	650	7000
30	736	1651	700	700	9000
32	781	1778	740	750	9800
34	832	1930	770	780	12000
36	876	2083	820	800	14000
40	978	2337	900	900	19000
42	1022	2437	960	950	22000
48	1168	2540	1100	1100	26000

■ **Reduced Port(Class 600)**

Size(in)	d(mm)	D(mm)	L(mm)	H1(mm)	H2(mm)	WT(kg)
3×2×3	51	76	356	105	100	42
4×3×4	76	102	432	160	130	90
6×4×6	102	152	559	205	170	160
8×6×8	152	203	660	245	190	300
10×8×10	203	254	787	280	230	560
12×10×12	254	305	838	326	280	820
14×10×14	254	337	889	320	280	920
14×12×14	305	337	889	350	300	1200
16×12×16	305	387	991	350	300	1400
16×14×16	337	387	991	380	330	1400
18×16×18	387	438	1092	415	350	1700
20×16×20	387	489	1194	415	350	2100
22×18×22	438	489	1194	440	400	2400
24×20×24	489	591	1397	500	440	3300
30×24×30	591	736	1651	585	530	5900
36×30×36	736	876	2083	700	700	11000

■ **Notes**

- 1.Face-to-Face dimensions are according to API 6D
- 2.For 2"to 24" flanges are according to ASME B16.5
- 3.For over 24".flanges are according to ASME B16.47 series A.

■ Full Port(Class 900)

Size(in)	D(mm)	L(mm)	H1(mm)	H2(mm)	WT(kg)
2	51	368	105	100	50
3	76	381	160	130	80
4	102	457	205	170	150
6	152	610	245	190	360
8	203	737	280	230	620
10	254	838	326	280	1100
12	305	965	350	300	1600
14	324	1029	380	330	1450
16	375	1130	415	350	2200
18	425	1219	440	400	2800
20	473	1321	500	440	4250
22	524	1422	520	470	6500
24	572	1549	585	530	7000
26	669	1651	630	570	8000
28	667	1753	645	650	9500
30	714	1880	700	700	12500
32	762	2032	740	750	12000
34	808	2159	770	780	18000

■ Reduced Port(Class 900)

Size(in)	d(mm)	D(mm)	L(mm)	H1(mm)	H2(mm)	WT(kg)
3 × 2 × 3	51	76	381	105	100	55
4 × 3 × 4	76	102	457	160	130	100
6 × 4 × 6	102	152	610	205	170	220
8 × 6 × 8	152	203	737	245	190	450
10 × 8 × 10	203	254	838	280	230	560
12 × 10 × 12	254	305	965	326	280	820
14 × 10 × 14	254	337	1029	320	280	920
14 × 12 × 14	305	337	1029	350	300	1200
16 × 12 × 16	305	387	1130	350	300	1400
16 × 14 × 16	324	387	1130	380	330	1400
18 × 16 × 18	375	438	1219	415	350	1700
20 × 16 × 20	375	489	1321	415	350	2100
22 × 18 × 22	425	489	1321	440	400	2400
24 × 20 × 24	473	591	1549	500	440	3300
30 × 24 × 30	572	736	1880	585	530	5900
36 × 30 × 36	714	876	2286	700	700	11000

Notes:  
1.Face-to-Face dimensions are according to API 6D  
2.For 2"to 24" flanges are according to ASME B16.5  
3.For over 24".flanges are according to ASME B16.47 series A.

■ Full Port(Class 1500)

Size(in)	D(mm)	L(mm)	H1(mm)	H2(mm)	WT(kg)
2	51	368	110	105	60
3	76	470	165	130	100
4	102	546	220	170	210
6	146	705	260	230	500
8	194	832	310	290	850
10	241	991	370	360	1600
12	289	1130	430	440	2300
14	317	1257	450	450	2950
16	362	1384	500	600	4200

■ Reduced Port(Class 1500)

Size(in)	d(mm)	D(mm)	L(mm)	H1(mm)	H2(mm)	WT(kg)
3 × 2 × 3	51	76	470	110	105	70
4 × 3 × 4	76	102	546	165	130	130
6 × 4 × 6	102	146	705	220	170	300
8 × 6 × 8	146	194	832	260	230	580
10 × 8 × 10	194	241	991	310	290	1100
12 × 10 × 12	241	289	1130	370	360	1800
14 × 10 × 14	241	317	1257	370	360	2200
14 × 12 × 14	289	317	1257	430	440	2600
16 × 12 × 16	289	362	1384	430	440	2900
16 × 14 × 16	317	362	1384	450	450	3300
18 × 16 × 18	362	407	1537	500	600	500
20 × 16 × 20	362	457	1664	500	600	5600

■ Full Port(Class 2500)

Size(in)	D(mm)	L(mm)	H1(mm)	H2(mm)	WT(kg)
2	44.5	451	120	130	100
3	63.5	578	180	200	200
4	89	673	230	250	390
6	133	914	260	250	790
8	181	1022	400	350	1400
10	226	1270	450	420	2200
12	267	1422	520	510	3400

■ Reduced Port(Class 2500)

Size(in)	d(mm)	D(mm)	L(mm)	H1(mm)	H2(mm)	WT(kg)
3 × 2 × 3	44.5	63.5	578	120	130	170
4 × 3 × 4	63.5	89	673	180	200	280
6 × 4 × 6	89	133	914	260	250	520
8 × 6 × 8	133	181	1022	400	250	1100
10 × 8 × 10	181	226	1270	450	350	1700
12 × 10 × 12	226	267	1422	450	420	2600

■ Notes

1.Face-to-Face dimensions are according to API 6D  
2.For 2"to 24" flanges are according to ASME B16.5